

## ERSATZTEILLISTE | SPARE PARTS LIST

100-127 V 50/60 Hz | 220-240 V 50/60 Hz

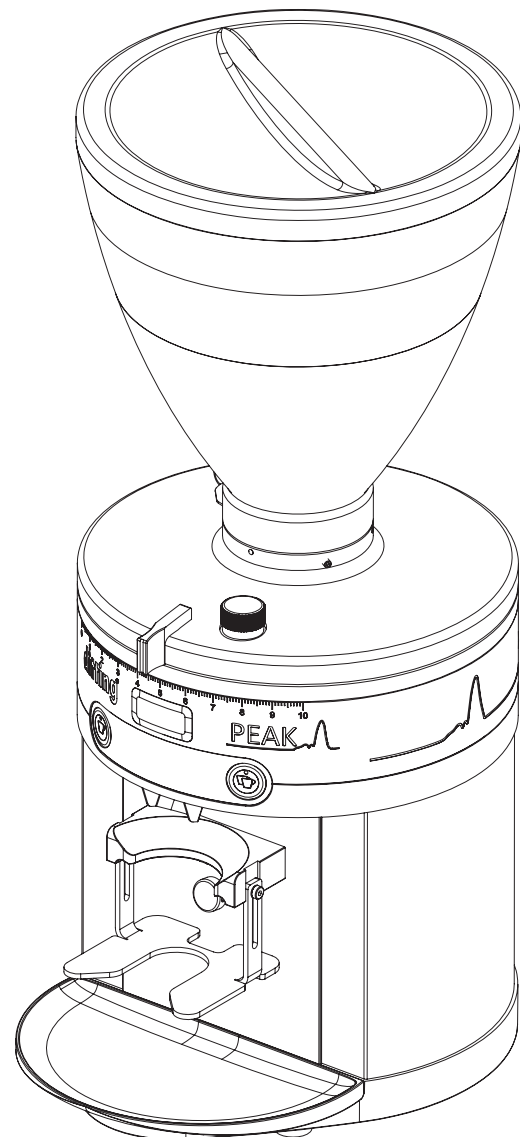

Bei Bestellungen bitte unbedingt die **sechsstellige Artikel- und Seriennummer** angeben.

Please indicate the **six digit article- and serial number** when ordering.

gültig ab | valid from  
2019-09-26

Änderungen ohne Vorankündigung vorbehalten.  
Subject to change without prior notice.

PEAK 100-127 V 50/60 Hz | 220-240 V 50/60 Hz

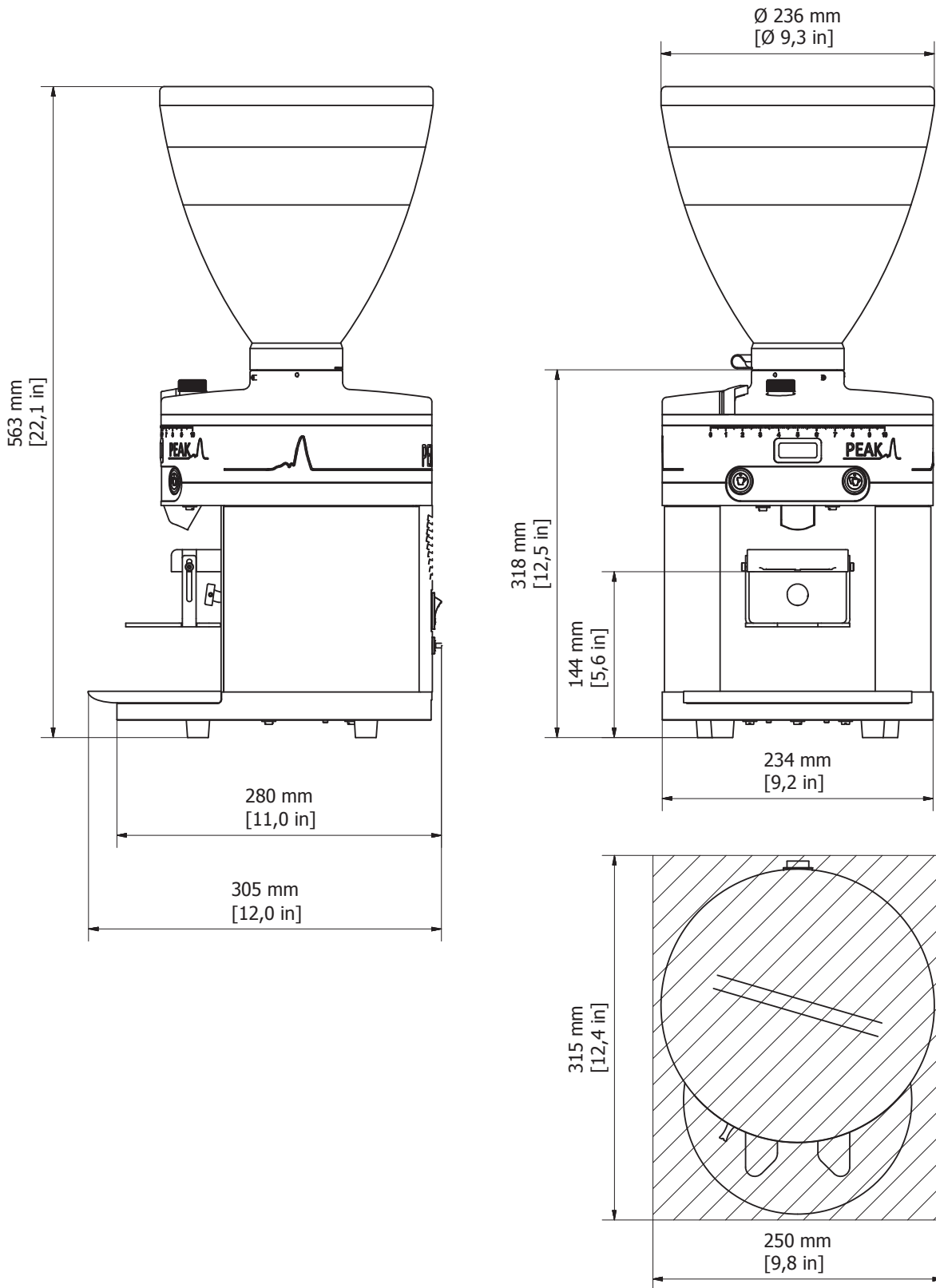

PEAK 100-127 V 50/60 Hz | 220-240 V 50/60 Hz

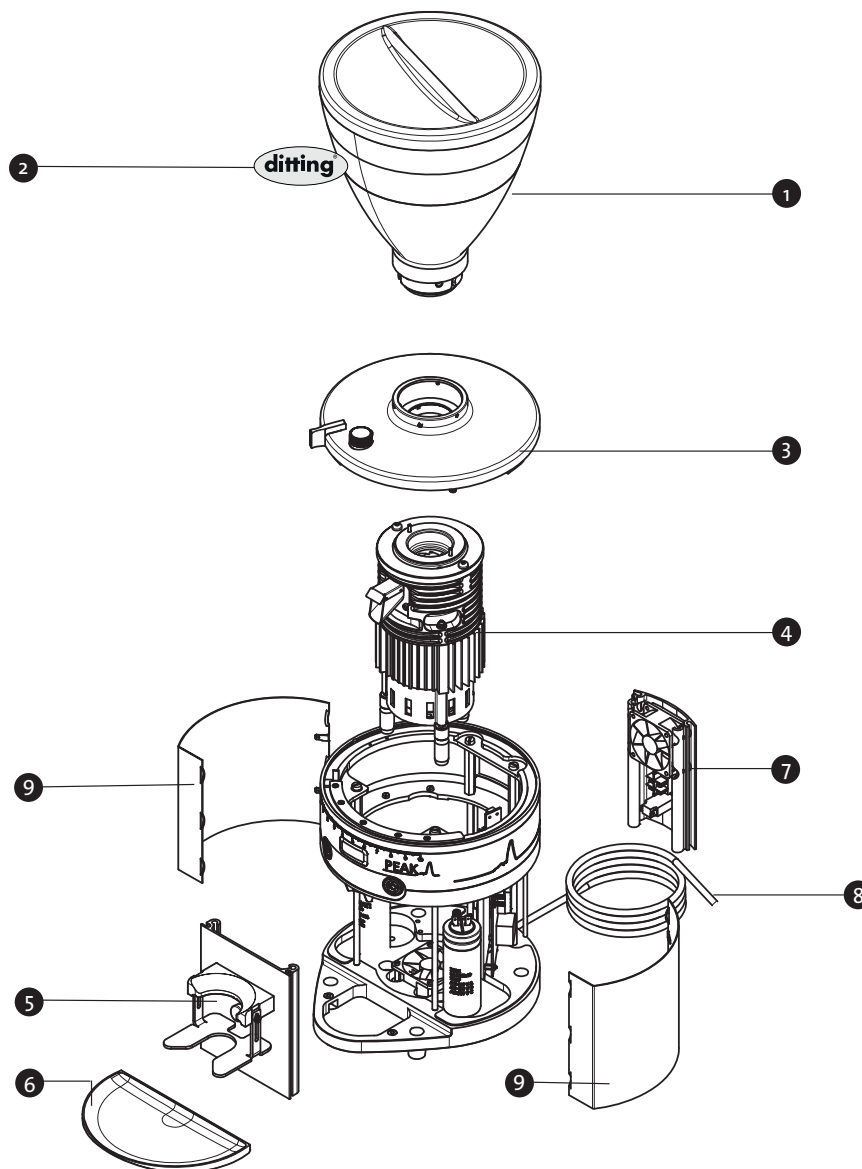

MATERI-	POS.	BESCHREIBUNG	DESCRIPTION
309560	1	Bohnenbehälter mit Deckel (ohne Logo)	Hopper with lid (without logo)
104680	2	Sticker transparent Ditting	Sticker transparent Ditting
104904	3	Deckel Mahlgradverstellung weiß UL, komplett	Cover grind adjustment white UL, complete
104905	3	Deckel Mahlgradverstellung weiß, komplett	Cover grind adjustment white, complete
700655	4	Einbaumühle 100-127 V 50/60 Hz 1100 rpm	Built-in grinder 100-127 V 50/60 Hz 1100 rpm
700657	4	Einbaumühle 220-240 V 50/60 Hz 1100 rpm	Built-in grinder 220-240 V 50/60 Hz 1100 rpm
701469	5	Vorderschale weiß, komplett	Front panel white, complete
306340	6	Auffangschale	Collecting tray
104909	7	Rückschale weiß 100-127 V, komplett	Back panel white 100-127 V, complete
104910	7	Rückschale weiß 220-240 V, komplett	Back panel white 220-240 V, complete
	8	Netzanschlussleitung (Auf Anfrage)	Power cord (on request)
104301	9	Dekoblech weiß	side panel white

PEAK 100-127 V 50/60 Hz | 220-240 V 50/60 Hz

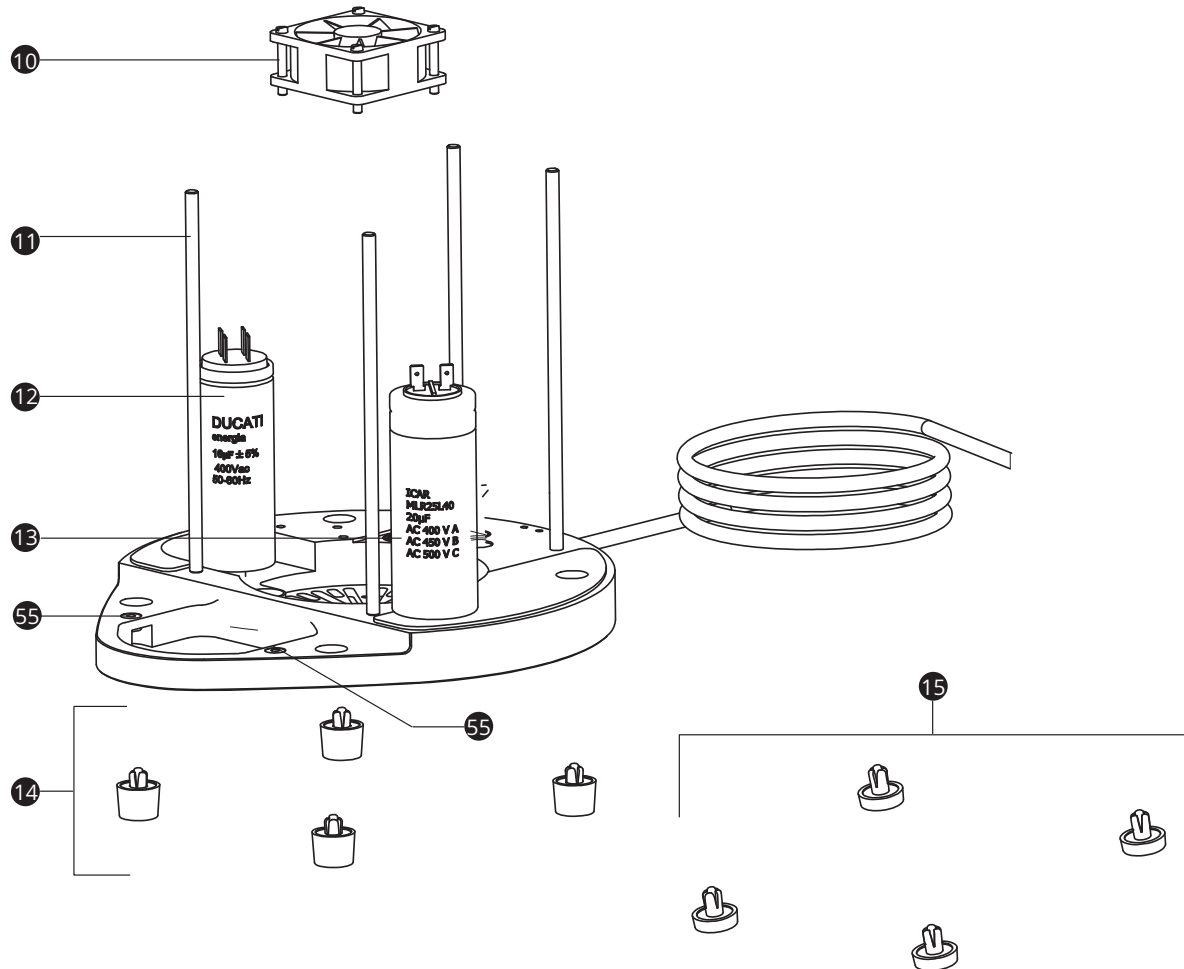

MATERI-	POS.	BESCHREIBUNG	DESCRIPTION
105308	10	Lüfter 12 VDC, Servicepack	Fan 12 VDC, service pack
104612	11	Gewindestangen, 4x	Threaded rods, 4x
257326	12	Betriebskondensator 16 µF 440 VAC	Operating capacitor 16 µF 440 VAC
104600	12	Betriebskondensator 60 µF 250 VAC	Operating capacitor 60 µF 250 VAC
310717	13	Startkondensator 20 µF 450 VAC	Starting capacitor 20 µF 450 VAC
105261	13	Startkondensator 40 µF 250 VAC	Starting capacitor 40 µF 250 VAC
700882	14	Gerätefüße hoch, ab Seriennr. 602646	Device feet high, from serial no. 602646
104613	15	Gerätefüße kurz, bis Seriennr. 602646	Device feet low, till serial no. 602646
309086	55	Durchführungsstülle, 10x	Grommet, 10x

PEAK 100-127 V 50/60 Hz | 220-240 V 50/60 Hz

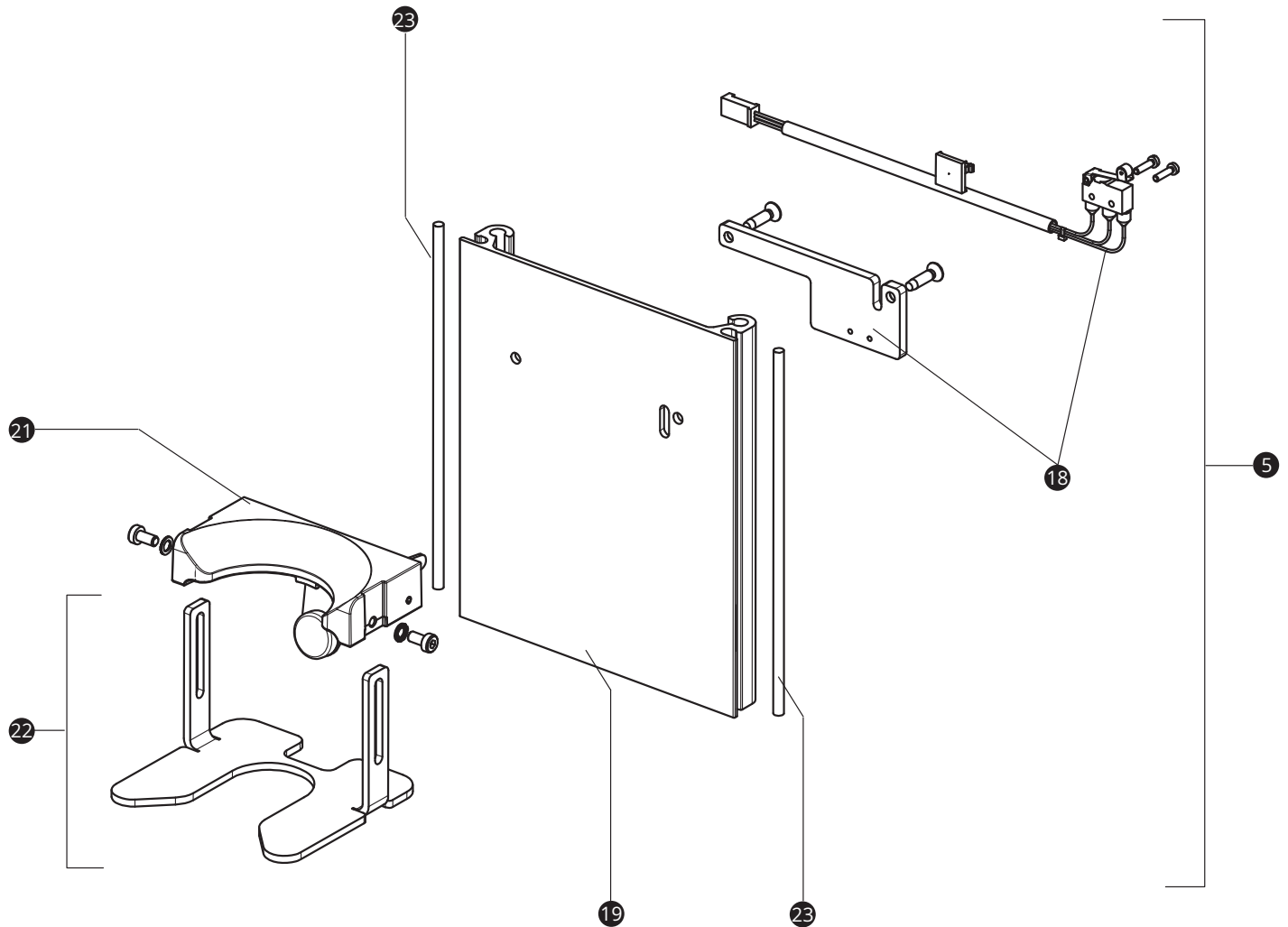

MATERIAL	POS.	BESCHREIBUNG	DESCRIPTION
701469	5	Vorderschale weiß, komplett	Front panel white, complete
701461	18	Mikroschalter, Servicepack	Micro switch, service pack
700514	19	Vorderschale weiß	Front panel white
701460	21	Siebträgeraufnahme, Servicepack	Portafilter mounting, - support, service pack
103053	22	Siebträgerauflage breit, 3 mm	Portafilter support wide, 3 mm
104597	22	Siebträgerauflage UL, Servicepack	Portafilter support UL, service pack
700900	23	Gummischnüre, 4x	Rubber cords, 4x

PEAK 100-127 V 50/60 Hz | 220-240 V 50/60 Hz

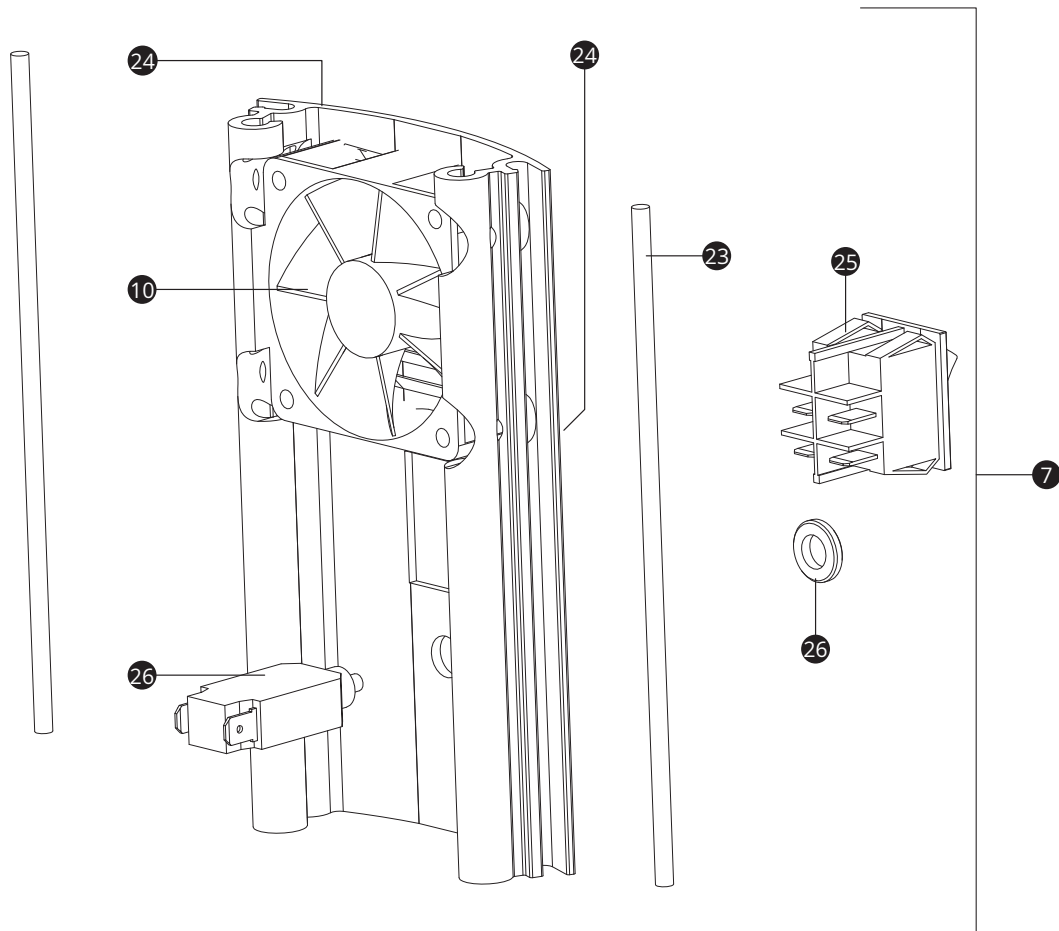

MATERI-	POS.	BESCHREIBUNG	DESCRIPTION
105304	7	Rückschale weiß 100-127 V , komplett	Back panel white 100-127 V, complete
104910	7	Rückschale weiß 220-240 V, komplett	Back panel white 220-240 V, complete
105308	10	Lüfter 12 VDC, Servicepack	Fan 12 VDC, service pack
700900	23	Gummischnüre, 4x	Rubber cords, 4x
700653	24	Rückschale weiß	Back panel white
102732	25	Wippenschalter	Rocker switch
306356	26	Geräteschutzschalter CBE-4A	Circuit breaker CBE-4A
308383	26	Geräteschutzschalter CBE-7A	Circuit breaker CBE-7A

PEAK 100-127 V 50/60 Hz | 220-240 V 50/60 Hz

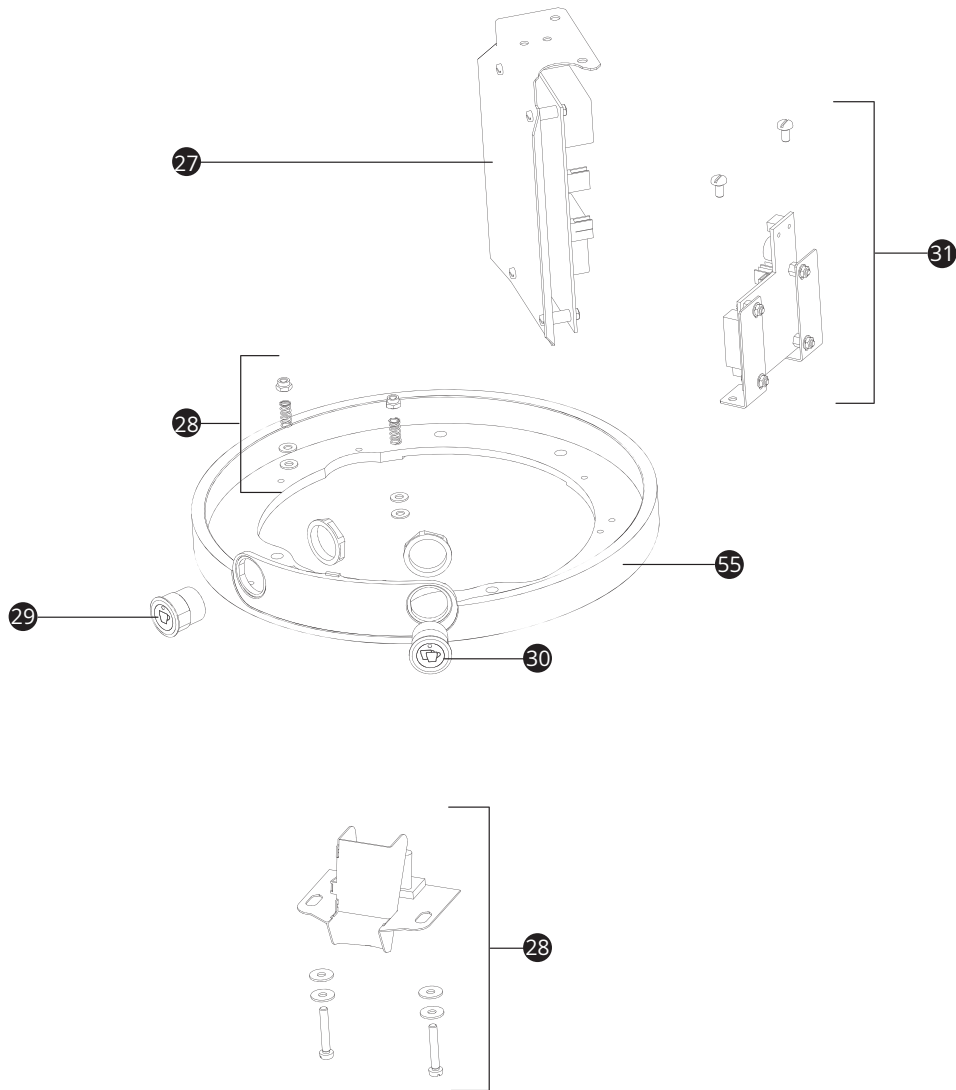

MATERI-	POS.	BESCHREIBUNG	DESCRIPTION
105081	27	Netzteil 100-240V 10W	Power board 100-240V 10W
104586	28	Verstellbarer Auslauf, komplett	Adjustable spout, complete
104136	29	Schalter "single shot" (LED blau)	Push button "single shot" (LED blue)
104091	29	Schalter "double shot" (LED blau) UL	Push button "double shot" (LED blue) UL
104135	30	Schalter "double shot" (LED blau)	Push button "double shot" (LED blue)
104090	30	Schalter "double shot" (LED blau) UL	Push button "double shot" (LED blue) UL
101007	31	Prozessorboard	Processor board
105114	56	Klemmring weiß	Clamp ring white

PEAK 100-127 V 50/60 Hz | 220-240 V 50/60 Hz

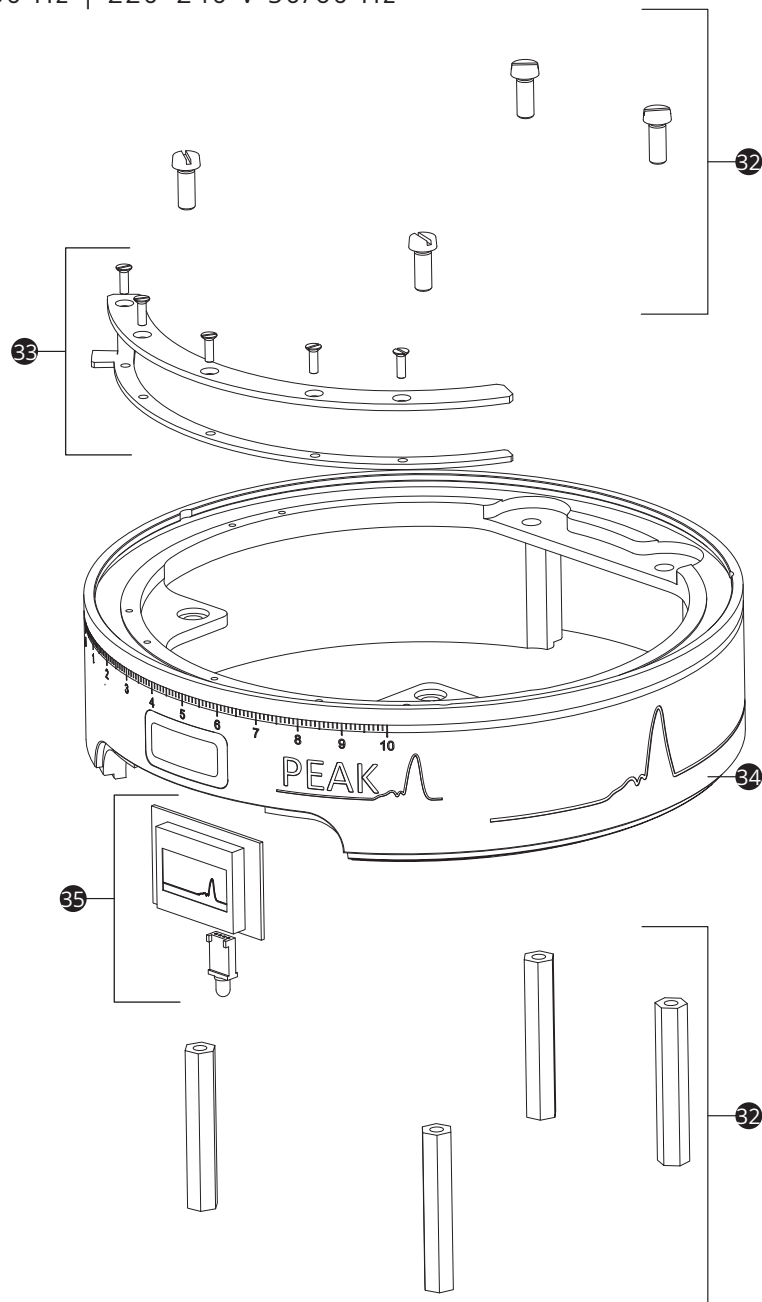

MATERI-	POS.	BESCHREIBUNG	DESCRIPTION
104574	32	Abstandschalter inkl. Schrauben	Spacers incl. screws
104582	33	Distanz- und Spannschiene, Servicepack	Distance- and clamping rail, service pack
104087	34	Dekoring PEAK Ditting weiß	Deco ring PEAK Ditting white
104584	35	Display inkl. LED	Display incl. LED



PEAK 100-127 V 50/60 Hz | 220-240 V 50/60 Hz

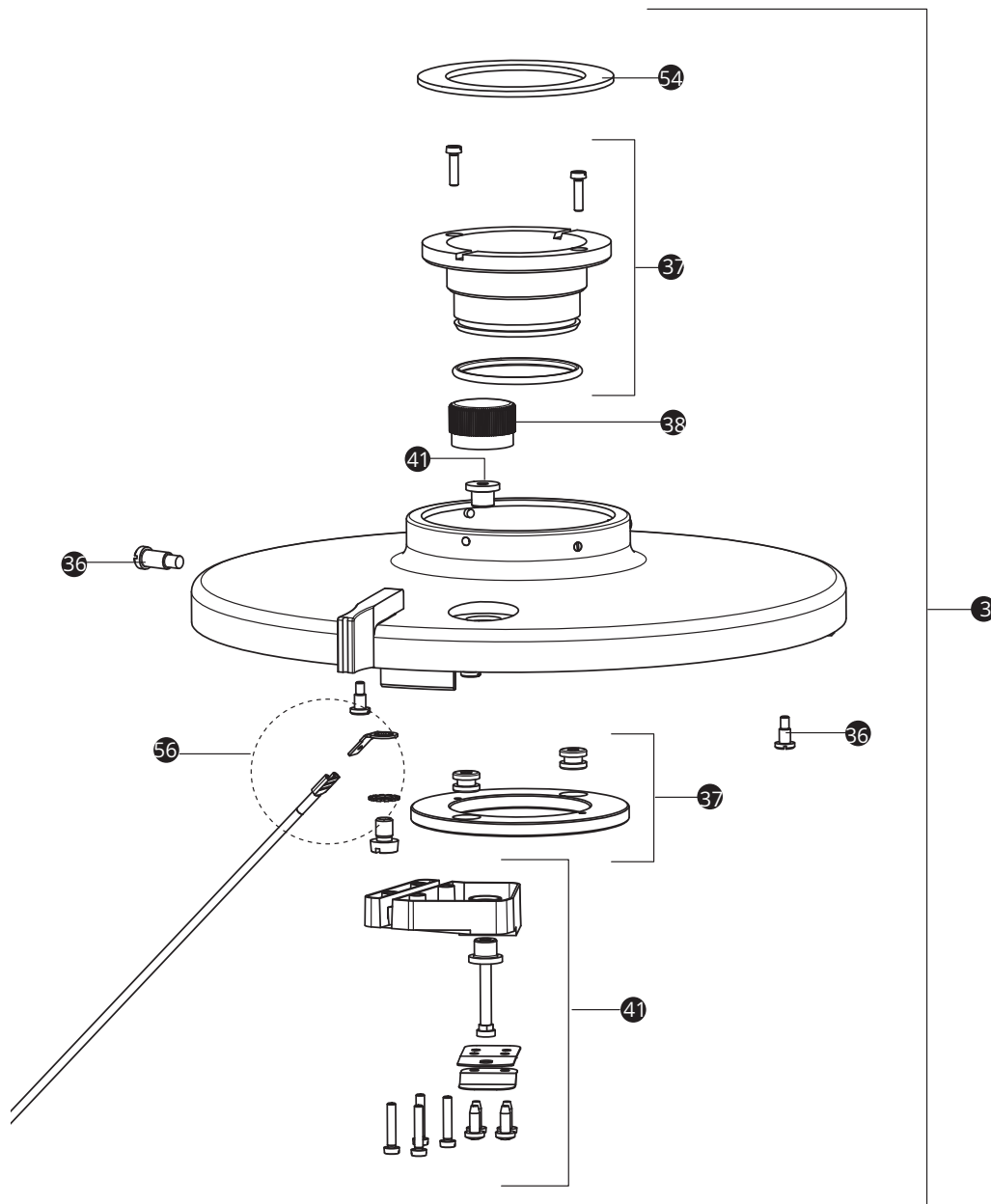

MATERI-	POS.	BESCHREIBUNG	DESCRIPTION
104904	3	Deckel Mahlgradverstellung weiß UL, komplett	Cover grind adjustment white UL, complete
104905	3	Deckel Mahlgradverstellung weiß, komplett	Cover with grind adjustment white, complete
104589	36	Schraubenset für den Deckel mit Mahlgradverstellung	Screw set for grinder cover
104591	37	Feinjustage Adapter, Servicepack	Fine adjustment adapter, service pack
308041	38	Entsperrknopf Mahlgradarretierung	Locking grind adjustment knob
104590	41	Mahlgradarretierung Kleinteileset, Servicepack	Locking grind adjustment, service pack
306389	54	Dichtring	Seal ring
701753	56	Erdung Deckel, Servicepack	Lid grounding, service pack

PEAK 100-127 V 50/60 Hz | 220-240 V 50/60 Hz

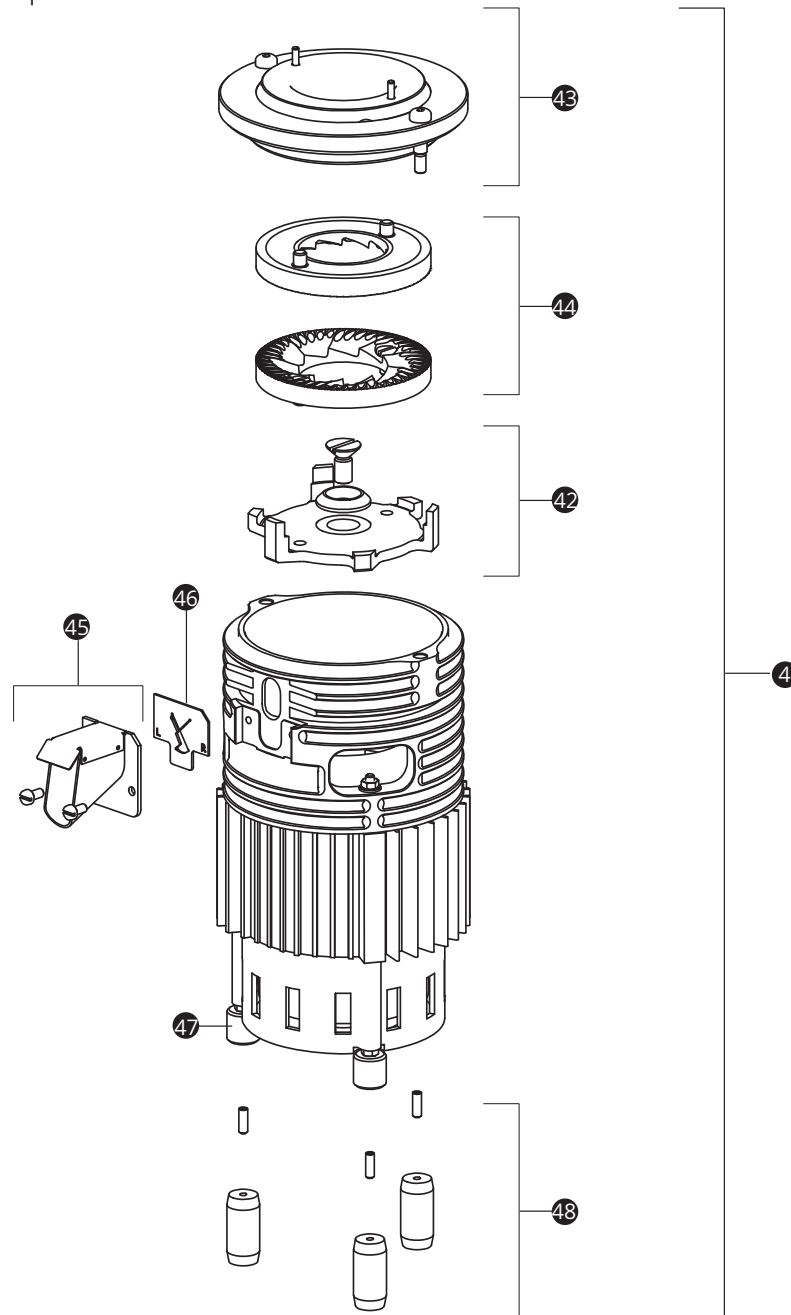

MATERI-	POS.	BESCHREIBUNG	DESCRIPTION
700655	4	Einbaumühle 100-127 V 50/60 Hz 1100 rpm	Built-in grinder 100-127 V 50/60 Hz 1100 rpm
700657	4	Einbaumühle 220-240 V 50/60 Hz 1100 rpm	Built-in grinder 220-240 V 50/60 Hz 1100 rpm
104946	42	Mahlscheibenträger drehend	Grinding disc carrier rotary
104948	43	Mahlscheibenträger fest	Grinding disc carrier fixed
103993	44	Mahlscheibensatz	Grinding disc set
104949	45	Auslauf Mahlgehäuse	Spout grinding chamber
104792	46	Silikon Flapper (60 Hz)	Silicone flapper (60 Hz)
103576	46	Silikon Flapper (50 Hz)	Silicone flapper (50 Hz)
309410	47	Schwingmetall-Puffer, 3x	Shock absorber, 3x
105310	48	Adapterbolzen	Adapter bolts

PEAK 100-127 V 50/60 Hz | 220-240 V 50/60 Hz

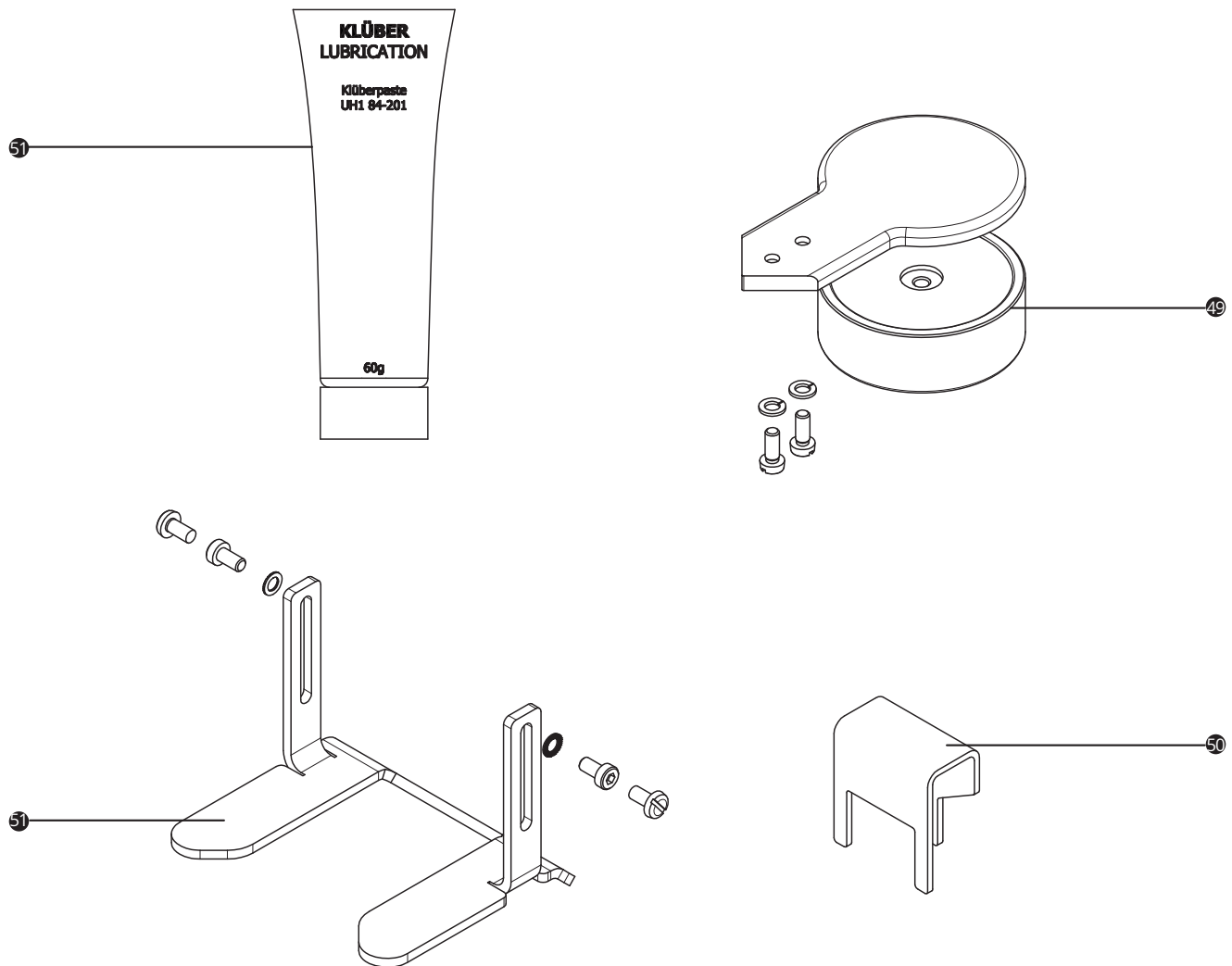

MATERI-	POS.	BESCHREIBUNG	DESCRIPTION
308660	49	Tamperanbausatz d = 53 mm	Tamper mounting kit d = 53 mm
308787	49	Tamperanbausatz d = 55 mm	Tamper mounting kit d = 55 mm
310490	49	Tamperanbausatz d = 57 mm	Tamper mounting kit d = 57 mm
307226	49	Tamperanbausatz d = 58 mm	Tamper mounting kit d = 58 mm
101066	50	Werkzeug für Mahlscheibenwechsel	Tool for disc change
700802	51	Siebeträgerauflage LM	Portafilter support LM
309336	52	Klüberpaste	Klüberpaste

## PEAK 100–127 V 50/60 Hz | 220–240 V 50/60 Hz

## ÄNDERUNGEN IN DER ERSATZTEILLISTE | CHANGES IN THE SPARE PARTS LIST

VERS.	MATERIAL	POS.	BESCHREIBUNG	DESCRIPTION	BEMERKUNG	COMMENT
2.0.1	104903	3	Deckel Mahlgradverstellung, komplett schwarz	Cover grind adjustment, complete black	neue Materialnummer	new material number
2.0.1	104905	3	Deckel Mahlgradverstellung, komplett weiß	Cover grind adjustment, complete white	neue Materialnummer	new material number
2.0.1	103212	4	Einbaumühle 100–127 V 60 Hz 1100 rpm	Built-in grinder 100–127 V 60 Hz 1100 rpm	neue Materialnummer	new material number
2.0.1	104953	4	Einbaumühle 220–240 V 60 Hz 1100 rpm	Built-in grinder 220–240 V 60 Hz 1100 rpm	neue Materialnummer	new material number
2.0.1	103014	4	Einbaumühle 220–240 V 50 Hz 900 rpm	Built-in grinder 220–240 V 50 Hz 900 rpm	neue Materialnummer	new material number
2.0.1	105304	7	Rückschale 100–127 V, komplett schwarz	Back panel 100–127 V, complete black	neue Materialnummer	new material number
2.0.1	105306	7	Rückschale 100–127 V, komplett weiß	Back panel 100–127 V, complete white	neue Materialnummer	new material number
2.0.1	104796	7	Rückschale 220–240 V, komplett schwarz	Back panel 220–240 V, complete black	neue Materialnummer	new material number
2.0.1	104910	7	Rückschale 220–240 V, komplett weiß	Back panel 220–240 V, complete white	neue Materialnummer	new material number
2.0.1	700882	14	Gerätefüße hoch	Device feet high	Ersetzt ab Serialnr. 602646 Gerätefüße kurz	Replaced from serial no. 602646 device feet low
2.0.1	306720	18	Mikroschalter, Servicepack	Micro switch	neue Materialnummer	new material number
2.0.1	104595	20	Schaltwippenknopf, Service Pack	Rocker switch knob, service pack	neue Materialnummer	new material number
2.0.1	104597	22	Siebträgerauflage	Portafilter support	neue Materialnummer	new material number
2.0.1	306566	23	Gummischnüre, 4x	Rubber cords, 4x	neue Materialnummer	new material number
2.0.1	103040	24	Rückschale schwarz	Back panel black	neue Materialnummer	new material number
2.0.1	104085	24	Rückschale weiß	Back panel white	neue Materialnummer	new material number
2.0.1	308383	26	Geräteschutzschalter CBE-7A	Circuit breaker CBE-7A	neue Materialnummer	new material number
2.0.1	105309	27	Netzteil 100–240 V 10 W	Powerboard 100–240 V 10 W	neue Materialnummer	new material number
2.0.1	104618	29	Schalter „single shot“ (LED blau)	Push button „single shot“ (LED blue)	neue Materialnummer	new material number
2.0.1	104619	30	Schalter „double shot“ (LED blau)	Push button „double shot“ (LED blue)	neue Materialnummer	new material number
2.0.1	309410	47	Schwingmetall-Puffer, 3x	Shock absorber, 3x	neue Materialnummer	new material number

PEAK 100-127 V 50/60 Hz | 220-240 V 50/60 Hz

ÄNDERUNGEN IN DER ERSATZTEILLISTE | CHANGES IN THE SPARE PARTS LIST

3.0.0	700802	51	Siebträgerauflage LM	Portafilter support LM	neuer Artikel	new article
3.0.0	309336	52	Klüberpaste	Klüberpaste	neuer Artikel	new article
3.0.0	306389	54	Dichtring	Seal ring	neuer Artikel	new article
3.0.1	309086	55	Durchführungstülle	Grommet	neuer Artikel	new article
3.0.1	104580	5	Vorderschale, komplett schwarz	Front panel, complete black	ersetzt durch 701468	replaced by 701468
3.0.1	104906	5	Vorderschale, komplett weiß	Front panel, complete black	ersetzt durch 701469	replaced by 701469
3.0.1	104594	16	Schraubenset für Schaltwippe	Screw set for rocker switch	entfällt	deleted
3.0.1	104593	17	Schaltwippe, Service-pack	Rocker switch, service pack	entfällt	deleted
3.0.1	700884	18	Mikroschalter, Service-pack	Micro switch, service pack	ersetzt durch 701461, Mikroschalter, Service-	replaced by 701461, Micro switch, service pack
3.0.1	104286	19	Vorderschale, schwarz	Front panel, schwarz	ersetzt durch 700436, Vorderschale	replaced by 700436, Front panel
3.0.1	104287	19	Vorderschale, weiß	Front panel, white	ersetzt durch 700514, Vorderschale	replaced by 700514, Front panel
3.0.1	306722	20	Schaltwippenknopf, Servicepack UL	Rocker switch knob, service pack UL	entfällt	deleted
3.0.1	307425	21	Siebträgeraufnahme	Portafilter mounting	in Mat.Nr. 701460 integriert	in Mat.No. 701460 integrated
4.0.1	103053	22	Siebträgerauflage breit, 3 mm	Portafilter support wide, 3 mm	separat erhältlich	separate available
5.0.0	700654	4	Einbaumühle 100-120 V 50 Hz 900 rpm	Built-in grinder 100-120 V 50 Hz 900 rpm	ersetzt durch 700655	replaced by 700655
5.0.0	700656	4	Einbaumühle 220-240 V 50 Hz 900 rpm	Built-in grinder 220-240 V 50 Hz 900 rpm	ersetzt durch 700657	replaced by 700657
5.0.0	105113	55	Klemmring weiß	Clamping ring white	neuer Artikel	new article
5.0.0	701753	56	Erdung Deckel, Service-pack	Lid grounding, service pack	neuer Artikel	new article